

Dear Supplier,

Because of recent escapes regarding First Article Inspection Reports, we would like to refresh method of record drawing characteristic on FAIR.

Please make sure, **each** drawing characteristic is:

- analyzed and answered,
- marked separately (each characteristic should have own balloon number),
- measurement results should available and recorded for each balloon,
- complex characteristics (including drawing notes) should have balloon number associated with individual characteristic (see example blow).

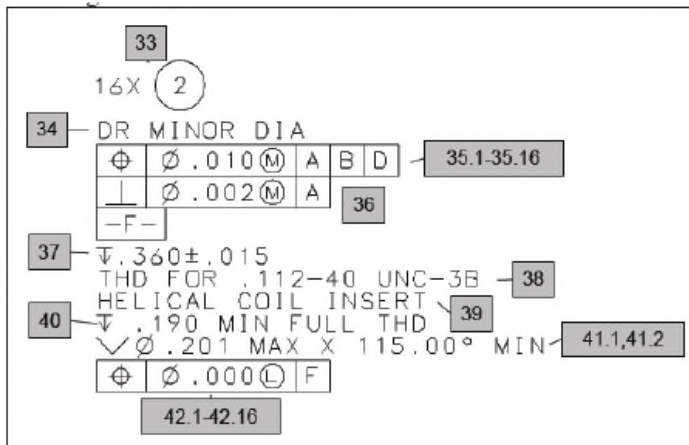

Example:

- characteristic no. 35 – balloons 35.1-35.16: 16x TP (with reference to characteristic no. 33),
- characteristic no. 41 – balloons 41.1 – 41.2: separate balloons for max diameter and angular position,
- characteristic no. 42 – balloons 42.1 – 42.16: 16x TP (with reference to characteristic no. 33),

